

Electronic Transformer

150 Watt RS-KO Series

DIMENSIONS

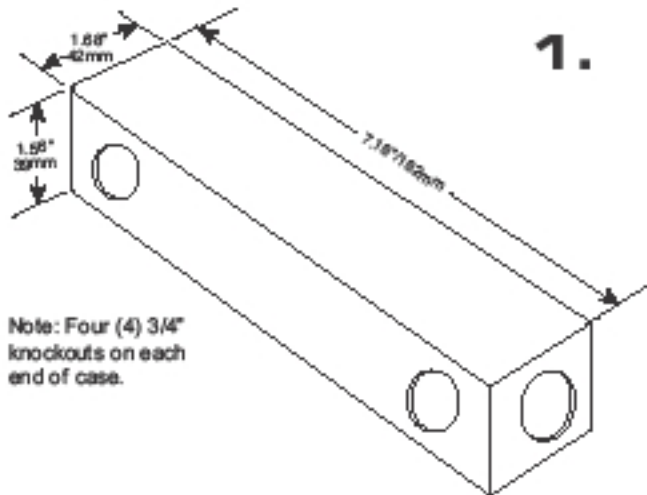

Note: Four (4) 3/4" knockouts on each end of case.

WIRING DIAGRAMS

DIAGRAM A

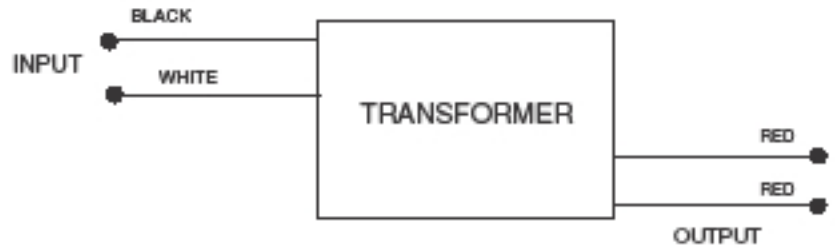

HARDWIRE ELECTRONIC

Max Watts	Min Watts	Input Volts	Input Amps	Output Volts	Output Amps	Case Style	Wiring Dia.	Hatch Item No.	Safety Listing
150	10	120	1.25	11.5	13.05	1	A	RS12-150KO	UL/C-UL Listed
				23.5	6.39	1	A	RS24-150KO	

*Note: Must use a minimum of 20 watts when using dimmers. It is also important to confirm dimming controls compatibility with the manufacturer and your Hatch representative.

Specifications subject to change without notice. 0009

HATCH